



Designers and Manufacturers of Retail Solutions for Over 60 Years

# KNM985

LARGE METAL SCANNER CART W/ STATIC CHILD SEAT



Perfect for large retailers looking to increase shopping capacity. Heavy-duty oval frame allows for a greater weight carrying capacity and significantly less maintenance.

The static child seat creates additional carrying capacity while eliminating the moving parts of traditional child gate assemblies. This leads to a longer life expectancy with less maintenance. Child restraints do not get tangled in nested carts, creating less cart sticking problems or damage to child restraints.

The **newly engineered gate design** is substantially stronger, ensuring that the swinging gate assembly doesn't bend or fail under heavy use.

Our patent-pending **Roller Lift System** was designed and engineered to avoid the most common caster lift failures, extending the life of the lift and the cart's wheels.

The strategic placement of a **rear brace bar** was designed to prevent customer shin bruising, a common occurrence caused by abrupt stops with cart containment systems.

## PRODUCT SPECIFICATIONS:

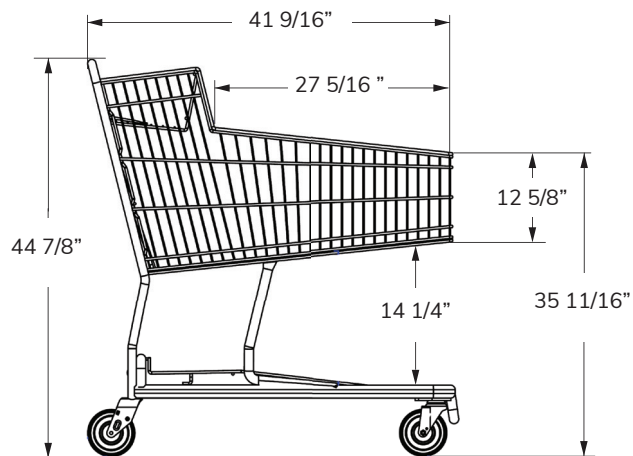
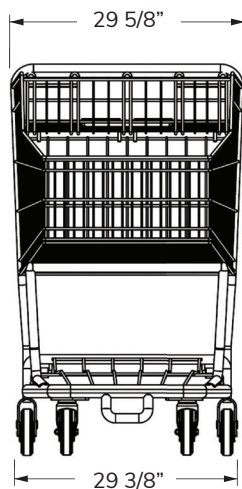

### Total Capacity

18,989 cu. in.  
311 liters

### Basket Capacity

11,995 cu. in.  
196.5 liters

### Nesting Distance

13 3/4 in  
35 cm

### Weight

66 lbs  
30 kg



# KNM785

LARGE METAL SCANNER CART W/ STATIC CHILD SEAT

## FEATURES:

- Available in any color finish or texture
- Meets all ASTM F2372-15R21 Standards
- Choice of plastic handle and seat color
- Store name or logo imprint on handle
- Seat belt
- Rust/weather-resistant finish
- Caster Roller Lifts
- Double-rim wire construction eliminates sharp edges at all touch-points around the basket while adding rigidity and strength
- Welded lower tray means less maintenance, less rusting and quieter cart operation in store



## FINISH COLORS:



Black Gloss  
Textured

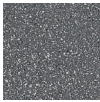

Granite  
Textured

Additional Finishes available: Textured Granite, Gloss Black, Flat Black, Red, Green, Blue, Orange, Yellow.

## PLASTIC COLORS:

Applies to handles and seats.



Black



Gray



Red



Blue



Dark Green

Contact your Peggs representative for a complete list of the available plastic colors.

Minimum quantities apply for custom metal finish and plastic colors.



Patent-pending Roller Lift System

## OPTIONAL ACCESSORIES:



Cup Holder, Coupon/Phone Convenience Tray, Purse Hook



P&H Super Wheels, TPE Soft and Quiet Runner Wheels



Optional Corner Bumpers in Standard Black or Gray



Cart containment systems: Gatekeeper, Cartronics, Rocateq, etc.