



KNM718

DEEP SCANNER METAL CART



Deep Scanner basket is perfect for large retailers looking to increase shopping capacity and shopper experience. Heavy-duty frame allows for increased weight and storage.

Double-Rim Wire Construction eliminates sharp edges at all touchpoints around the basket while adding rigidity and strength.

Welded Lower Tray means less maintenance, less rusting and quieter cart operation in store.

Forever Secure gate design ensures the gate assembly that holds the child can never fall off, or out of the cart.

Gravity-Drop Seat Frame ensures a smooth and effortless closing of the child seat when the gate closes, significantly reducing the chances of seat belts and components getting tangled in the operation.

FEATURES:

- Available in any color finish or texture
- Meets all ASTM F2372-15R21 Standards
- Choice of plastic handle and seat color
- Custom logo imprint
- Seat belt
- Rust/weather-resistant finish

OPTIONS:

- Cup holder, phone/convenience tray
- Purse hook
- Corner bumpers
- P&H Super Wheels, TPE Soft and Quiet Runner wheels
- Cart containment: Gatekeeper Systems, Carttronics, Rocateq, etc.

PRODUCT SPECIFICATIONS:

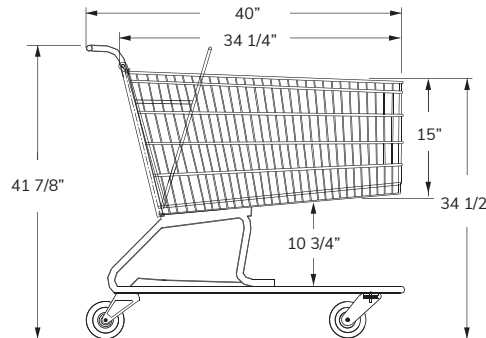
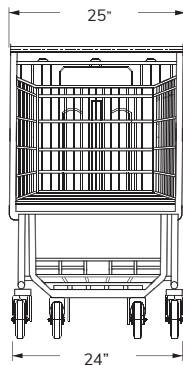

Total Capacity

20,000 in³
327.7 liters

Basket Capacity

14,150 in³
231.8 liters

Nesting Distance

12 in
30.4 cm

Weight

63 lbs
28.5 kg

