



Designers and Manufacturers of Retail Solutions for Over 60 Years

# KNM655

DEEP SCANNER PLASTIC CART WITH ANTI-THEFT FRAME



Plastic cart with an anti-theft frame is constructed using oval tubing for superior durability and rigidity. Plastic baskets reduce the cart's overall weight and protect store equipment and fixtures from damage. Additionally, plastic baskets minimizing liability in parking lots as they are less likely to scratch or damage vehicles.

Colored basket and side panels complement store design and reinforce store branding.

**Anti-theft design** prevents storage of items under basket, reducing below-basket shrink.

**Gravity-Drop Seat Frame** ensures a smooth and effortless closing of the child seat when the gate closes, significantly reducing the chances of seat belts and components getting tangled in the operation.

**Forever Secure** gate design ensures the gate assembly that holds the child can never fall off, or out of the cart.

## FEATURES:

- Available in any color finish or texture
- Meets all ASTM F2372-15R21 Standards
- Choice of plastic basket color
- Custom logo imprint
- Seat belt
- Rust/weather-resistant finish

## OPTIONS:

- Cup holder, phone/convenience tray
- Purse hook
- P&H Super Wheels, TPE Soft and Quiet Runner wheels
- Cart containment: Gatekeeper Systems, Carttronics, Rocateq, etc.

## PRODUCT SPECIFICATIONS:

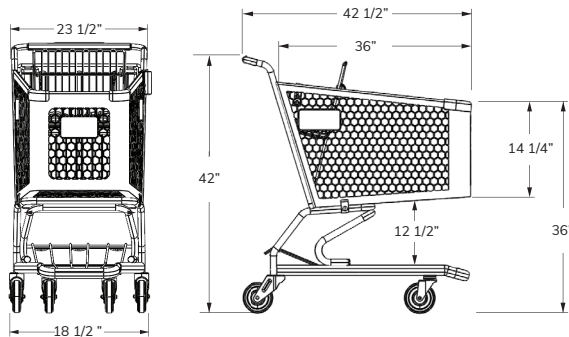

### Total Capacity

10,300 in<sup>3</sup>  
168.7 liters

### Basket Capacity

10,300 in<sup>3</sup>  
168.7 liters

### Nesting Distance

12 in  
30.4 cm

### Weight

58 lbs  
26.3 kg

