



KNM530

MEDIUM PLASTIC CART - LOW FRAME

This mid-sized shopping cart features a low frame and plastic basket. Panels on three basket sides provide space for logos to reinforce store branding.

In addition to limiting damage to store equipment and fixtures, plastic baskets lessen liability in parking lots as they are less likely to scratch or damage vehicles.

Choice of plastic basket color: Black, Grey, Red, Royal Blue, Dark Blue, Dark Green, Orange, Yellow, Beige.

FEATURES:

- Available in any color finish or texture
- Meets all ASTM F2372-15R21 Standards
- Choice of plastic basket color: Black, Grey, Red, Royal Blue, Dark Blue, Dark Green, Orange, Yellow, Beige
- Custom logo imprint
- Seat belt
- Rust/weather-resistant finish

OPTIONS:

- Cup holder, phone/convenience tray
- Purse hook
- P&H Super Wheels, TPE Soft and Quiet Runner wheels
- Cart containment: Gatekeeper Systems, Cartronics, Rocateq, etc.

PRODUCT SPECIFICATIONS:

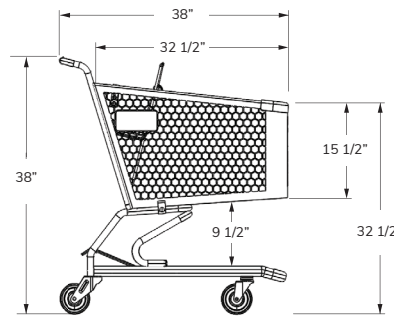
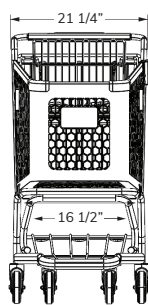

Total Capacity

11,100 in³
181.8 liters

Basket Capacity

7,945 in³
130 liters

Nesting Distance

10 3/4 in
27.3 cm

Weight

42 lbs
19 kg

