



# KNM060

## HANDI-AID SHOPPING CART

This cart easily adjusts to the customers' wheelchairs via two Velcro straps. Redesigned to be more stable, safer to operate and more user-friendly than other Handi-Aid shoppers on the market. Standard color - ADA blue. *Wheelchair sold separately.*



### FEATURES:

- Standard finish: ADA Blue
- Custom logo imprint
- 5" polyurethane swivel casters
- Rust/weather-resistant finish

### OPTIONS:

- Optional Granite or Yellow finish
- Corner bumpers
- P&H Super Wheels, TPE Soft and Quiet Runner wheels

### PRODUCT SPECIFICATIONS:

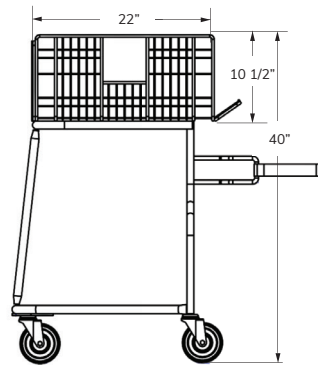
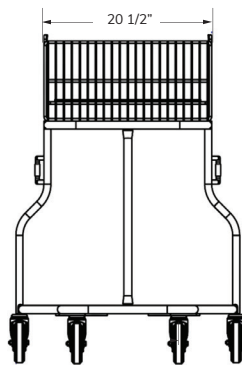

#### Total Capacity

4,735 in<sup>3</sup>  
77.5 liters

#### Weight

36 lbs  
16 kg