



KNS2538NCPLF

NURSERY CART W/ PLASTIC FLIP TOP DECK

Designed for nurseries and garden centers, this nestable two-tier cart features a steel frame, durable plastic shelves and a flip-top deck. Available in standard or heavy-duty and suited for indoor/outdoor use.

KNS2538NCPLF – Standard Duty

Features 5" rear poly wheels

KNS2538NCPLFHD – Heavy Duty

Features 8" rear semi-pneumatic wheels

OPTIONS:

- Frame available in any color finish or texture
- P&H Super Wheels (exceptionally quiet, longer lifespan, added durability)
- Rear swivel or rigid caster options
- With or without top basket



PRODUCT SPECIFICATIONS:

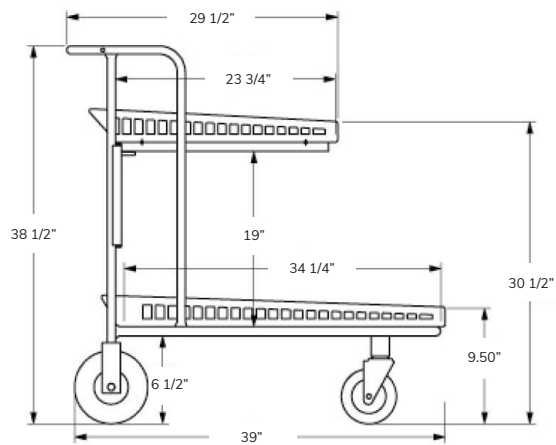
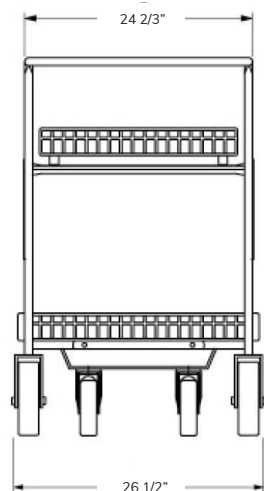

Load Capacity

600 lbs
272 kg

Weight

62 lbs
28 kg

Nesting Distance

19 in
48.3 cm

