



# KNM800

## LARGE "MAGNUM" METAL CART



This large, heavy-duty frame substantially increases load capacity of the cart as well as its ability to withstand store environments that are high-volume and subject to heavy abuse. Perfect for large retailers looking to increase shopping capacity and shopper experience.

**Gravity-Drop Seat Frame** ensures a smooth and effortless closing of the child seat when the gate closes, significantly reducing the chances of seat belts and components getting tangled in the operation.

**Double-Rim Wire Construction** eliminates sharp edges at all touchpoints around the basket while adding rigidity and strength.

**Forever Secure** gate design ensures the gate assembly that holds the child can never fall off, or out of the cart.

**Welded Lower Tray** means less maintenance, less rusting and quieter cart operation in-store.

### FEATURES:

- Available in any color finish or texture
- Meets all ASTM F2372-15R21 Standards
- Choice of plastic handle and seat color
- Custom logo imprint
- Seat belt
- Rust/Weather resistant finish

### OPTIONS:

- Cup holder, phone/convenience tray
- Purse hook
- Corner bumpers
- P&H Super Wheels, TPE Soft and Quiet Runner wheels
- Cart containment: Gatekeeper Systems, Carttronics, Rocateq, etc.

### PRODUCT SPECIFICATIONS:

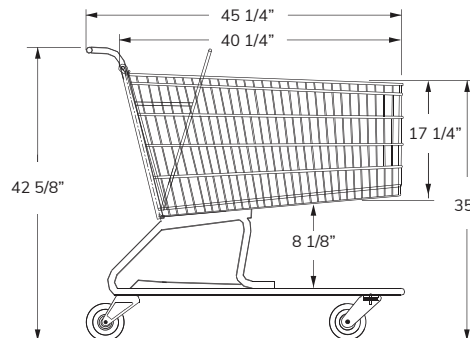
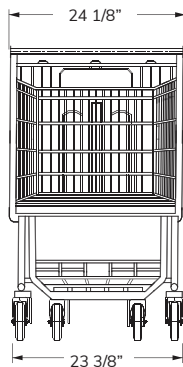

#### Total Capacity

20,321 in<sup>3</sup>  
333 liters

#### Basket Capacity

15,586 in<sup>3</sup>  
255.41 liters

#### Nesting Distance

13 5/8"  
34.61 cm

#### Weight

67 lbs  
30.3 kg

