



KNM740

DEEP SCANNER METAL CART

Deep Scanner basket is perfect for large retailers looking to increase shopping capacity and shopper experience. Heavy-duty frame allows for increased weight and storage.

Double-Rim Wire Construction eliminates sharp edges at all touchpoints around the basket while adding rigidity and strength.

Welded Lower Tray means less maintenance, less rusting and quieter cart operation in store.

Forever Secure gate design ensures the gate assembly that holds the child can never fall off, or out of the cart.

Gravity-Drop Seat Frame ensures a smooth and effortless closing of the child seat when the gate closes, significantly reducing the chances of seat belts and components getting tangled in the operation.

FEATURES:

- Available in any color finish or texture
- Meets all ASTM F2372-15R21 Standards
- Choice of plastic handle and seat color
- Custom logo imprint
- Seat belt
- Rust/weather-resistant finish

OPTIONS:

- Cup holder, phone/convenience tray
- Purse hook
- Corner bumpers
- P&H Super Wheels, TPE Soft and Quiet Runner wheels
- Cart containment: Gatekeeper Systems, Carttronics, Rocateq, etc.

PRODUCT SPECIFICATIONS:

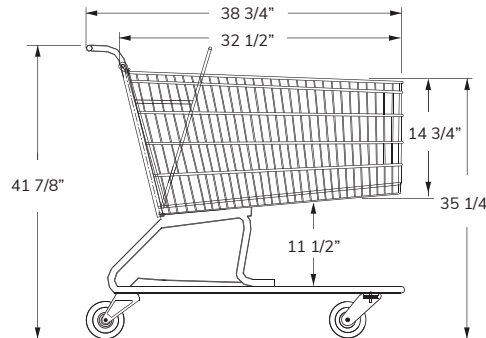
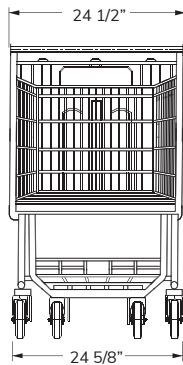

Total Capacity

14,268 in³
233.81 liters

Basket Capacity

10,465 in³
171.49 liters

Nesting Distance

9 3/4 in
24.77 cm

Weight

57 lbs
25.85 kg

