



Designers and Manufacturers of Retail Solutions for Over 60 Years

KNM700

DEEP SCANNER METAL CART



Deep Scanner basket is perfect for large retailers looking to increase shopping capacity and shopper experience. Heavy-duty frame allows for increase weight and storage.

Double-Rim Wire Construction eliminates sharp edges at all touch-points around the basket while adding rigidity and strength.

Welded Lower Tray means less maintenance, less rusting and quieter cart operation in store.

Forever Secure gate design ensures the gate assembly that holds the child can never fall off, or out of the cart.

Gravity-Drop Seat Frame ensures a smooth and effortless closing of the child seat when the gate closes, significantly reducing the chances of seat belts and components getting tangled in the operation.

PRODUCT SPECIFICATIONS:

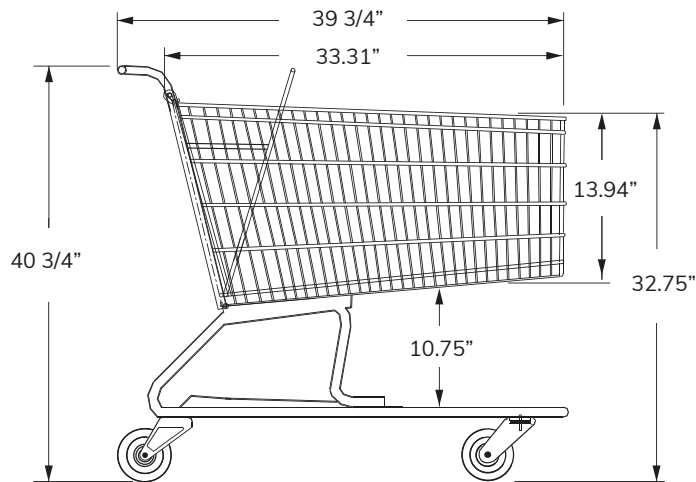
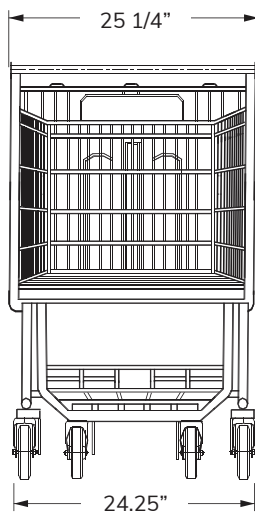

Total Capacity

18,000 cu. in.
295 liters

Basket Capacity

12,400 cu. in.
203 liters

Nesting Distance

12 3/4 in
32.4 cm

Weight

66 lbs
29.9 kg



KNM700

DEEP SCANNER METAL CART

FEATURES:

- Available in any color finish or texture
- Meets all ASTM F2372-15R21 Standards
- Choice of plastic handle and seat color
- Store name or logo imprint on handle
- Seat belt
- Rust/weather-resistant finish

FINISH COLORS:



Black Gloss
Textured

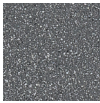

Granite

Additional Finishes available: Textured Granite, Gloss Black, Flat Black, Red, Green, Blue, Orange, Yellow.

PLASTIC COLORS:

Applies to handles and seats.

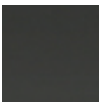

Black

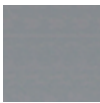

Gray



Red



Blue



Dark Green

Contact your Peggs representative for a complete list of the available plastic colors.

Minimum quantities apply for custom metal finish and plastic colors.

OPTIONAL ACCESSORIES:



Cup Holder, Coupon/Phone
Convenience Tray, Purse Hook



P&H Super Wheels, TPE
Soft and Quiet Runner Wheels



Optional Corner Bumpers
in Standard Black or Gray



Cart containment systems:
Gatekeeper, Cartronics,
Rocateq, etc.

