



KNM675

PFLOW CART



Large plastic shopping cart designed to be used on the PFlow vertical transport system.

In addition to limiting damage to store equipment and fixtures, plastic baskets lessen liability in parking lots as they are less likely to scratch or damage vehicles.

Logo branding is available on three basket sides as well as the inside panel.

Forever Secure gate design ensures the gate assembly that holds the child can never fall off, or out of the cart.

FEATURES:

- Available in any color finish or texture
- Meets all ASTM F2372 Standards
- Choice of plastic basket color
- Custom logo imprint
- Seat belt
- Rust/weather-resistant finish

OPTIONS:

- Cup holder, phone/convenience tray
- Purse hook
- P&H Super Wheels, TPE Soft and Quiet Runner wheels
- Cart containment: Gatekeeper Systems
- Magnetic or Non-Magnetic PFlow Tow Bar

PRODUCT SPECIFICATIONS:

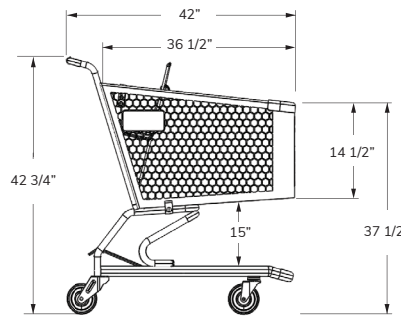
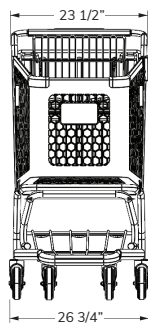

Total Capacity

9,750 in³
159.7 liters

Basket Capacity

9,750 in³
159.7 liters

Nesting Distance

12 in
30.48 cm

Weight

62 lbs
28 kg

