



KNM650

DEEP SCANNER PLASTIC CART

Plastic cart reduces overall weight and protects store equipment and fixtures from damage. The cart's frame is constructed using oval tubing for superior durability and rigidity.

In addition to limiting in-store damage, plastic baskets lessen liability in parking lots as they are less likely to scratch or damage vehicles.

Colored basket and customizable side panels support store branding. Plastic basket components can be rebuilt should one panel become damaged.

Gravity-Drop Seat Frame ensures a smooth and effortless closing of the child seat when the gate closes, significantly reducing the chances of seat belts and components getting tangled in the operation.

Forever Secure gate design ensures the gate assembly that holds the child can never fall off, or out of the cart.

FEATURES:

- Available in any color finish or texture
- Meets all ASTM F2372-15R21 Standards
- Choice of plastic basket color
- Custom logo imprint
- Seat belt
- Rust/weather-resistant finish

OPTIONS:

- Cup holder, phone/convenience tray
- Purse hook
- P&H Super Wheels, TPE Soft and Quiet Runner wheels
- Cart containment: Gatekeeper Systems, Carttronics, Rocateq, etc.

PRODUCT SPECIFICATIONS:

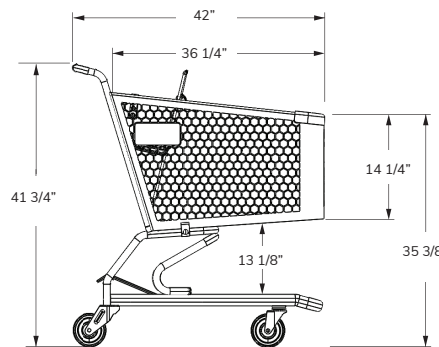
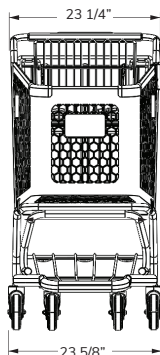

Total Capacity

18,711 in³
306.62 liters

Basket Capacity

11,013 in³
180.47 liters

Nesting Distance

11 7/8 in
30.16 cm

Weight

55 lbs
29.95 kg

