



KNM640

LARGE PLASTIC CART



This single-molded basket is lighter, quieter and easier to maneuver than a traditional shopping cart and the longer, higher capacity basket is a perfect fit for all stores.

In addition to limiting damage to store equipment and fixtures, plastic baskets lessen liability in parking lots as they are less likely to scratch or damage vehicles.

Three panels (on the sides and front of the basket) provide space to reinforce store branding.

FEATURES:

- Available in any color finish or texture
- Meets all ASTM F2372-15R21 Standards
- Choice of plastic basket color: Black, Grey, Red, Royal Blue, Dark Blue, Dark Green, Orange, Yellow, Beige
- Custom logo imprint
- Seat belt
- Rust/weather-resistant finish

OPTIONS:

- Cup holder, phone/convenience tray
- Purse hook
- P&H Super Wheels, TPE Soft and Quiet Runner wheels
- Cart containment: Gatekeeper Systems, Cartronics, Rocateq, etc.

PRODUCT SPECIFICATIONS:

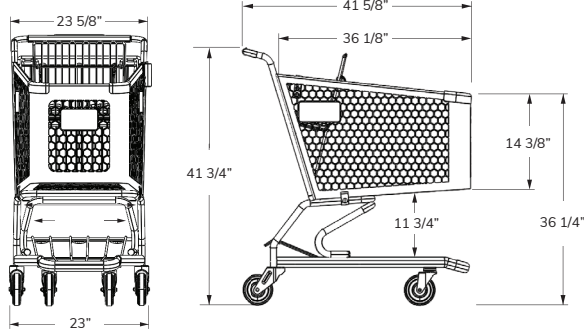

Total Capacity

17,666 in³
289.5 liters

Basket Capacity

11,464 in³
187.9 liters

Nesting Distance

11 5/8 in
29.5 cm

Weight

57 lbs
25.9 kg

