



# KNM600

## SMALL PLASTIC SCANNER CART



Plastic cart reduces overall weight and its shallow basket makes items easier to reach and unload. Colored basket and customizable side panels support store branding.

In addition to limiting damage to store equipment and fixtures, **Plastic Baskets** lessen liability in parking lots as they are less likely to scratch or damage vehicles.

**Gravity-Drop Seat Frame** ensures a smooth and effortless closing of the child seat when the gate closes, significantly reducing the chances of seat belts and components getting tangled in the operation.

**Forever Secure** gate design ensures the gate assembly that holds the child can never fall off, or out of the cart.

**Welded Lower Tray** means less maintenance, less rusting and quieter cart operation in store.

### FEATURES:

- Available in any color finish or texture
- Meets all ASTM F2372-15R21 Standards
- Choice of plastic basket color: Black, Grey, Red, Royal Blue, Dark Blue, Dark Green, Orange, Beige
- Custom logo imprint
- Seat belt
- Rust/weather-resistant finish

### OPTIONS:

- Cup holder, phone/convenience tray
- Purse hook
- P&H Super Wheels, TPE Soft and Quiet Runner wheels
- Cart containment: Gatekeeper Systems, Cartrronics, Rocateq, etc.

### PRODUCT SPECIFICATIONS:

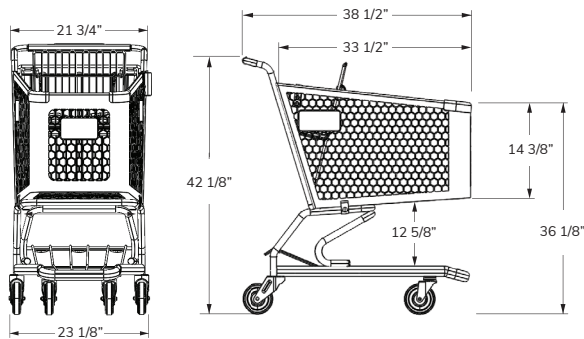

#### Total Capacity

13,748 in<sup>3</sup>  
225.3 liters

#### Basket Capacity

8,943 in<sup>3</sup>  
146.5 liters

#### Nesting Distance

12 1/4 in  
31.1 cm

#### Weight

52 lbs  
23.6 kg

