



KNM550

MEDIUM PLASTIC CART



This mid-sized cart features a plastic basket, reducing damage to store fixtures and equipment and is lighter, quieter and easier to maneuver than a traditional metal cart.

In addition to limiting damage to store equipment and fixtures, plastic baskets lessen liability in parking lots as they are less likely to scratch or damage vehicles.

Three panels (on the sides and front of the basket) provide space to reinforce store branding.

Gravity-Drop Seat Frame ensures a smooth and effortless closing of the child seat when the gate closes, significantly reducing the chances of seat belts and components getting tangled in the operation.

Forever Secure gate design ensures the gate assembly that holds the child can never fall off, or out of the cart.

FEATURES:

- Available in any color finish or texture
- Meets all ASTM F2372 Standards
- Choice of plastic basket color: Black, Grey, Red, Royal Blue, Dark Blue, Dark Green, Orange, Yellow, Beige
- Custom logo imprint
- Seat belt
- Rust/weather-resistant finish

OPTIONS:

- Cup holder, phone/convenience tray
- Purse hook
- P&H Super Wheels, TPE Soft and Quiet Runner wheels
- Cart containment: Gatekeeper Systems, Carttronics, Rocateq, etc.

PRODUCT SPECIFICATIONS:

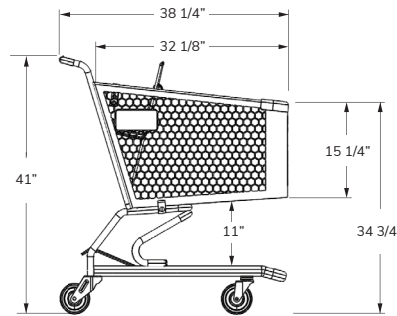
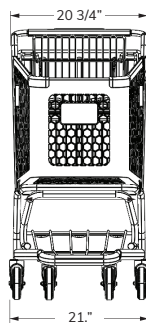

Total Capacity

12,656 in³
207.39 liters

Basket Capacity

7,967 in³
130.56 liters

Nesting Distance

9 7/8 in
25.08 cm

Weight

49 lbs
22.23 kg

