



KNM540

MEDIUM PLASTIC CART

This single-molded basket is lighter, quieter and easier to maneuver than a traditional cart. The narrow width is a perfect fit for all stores while providing plenty of shopping capacity.

A welded lower tray means less maintenance, less rusting and quieter cart operation in store.

In addition to limiting damage to store equipment and fixtures, plastic baskets lessen liability in parking lots as they are less likely to scratch or damage vehicles.

Three panels (on the sides and front of the basket) provide space to reinforce store branding.

FEATURES:

- Available in any color finish or texture
- Meets all ASTM F2372-15R21 Standards
- Choice of plastic basket color
- Custom logo imprint
- Seat belt
- Rust/weather-resistant finish

OPTIONS:

- Cup holder, phone/convenience tray
- Purse hook
- P&H Super Wheels, TPE Soft and Quiet Runner wheels
- Cart containment: Gatekeeper Systems, Carttronics, Rocateq, etc.

PRODUCT SPECIFICATIONS:

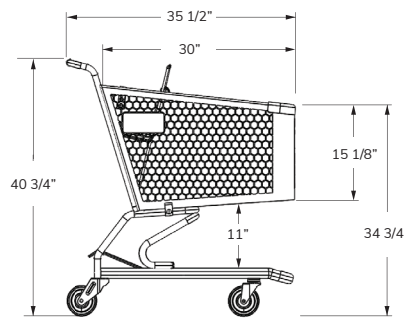
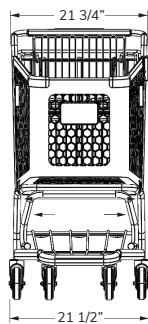

Total Capacity

12,230 in³
200 liters

Basket Capacity

7,511 in³
123 liters

Nesting Distance

10 3/4 in
27.3 cm

Weight

47 lbs
21 kg

