



Designers and Manufacturers of Retail Solutions for Over 60 Years

KNM440

JUMBO OTC CART



Large metal shopping basket designed to be used for over-the-counter equipped check stands.

Front gate drops down to provide easy access to groceries for unloading. Features under-basket storage for milk/soda in addition to a lower tray.

PRODUCT SPECIFICATIONS:

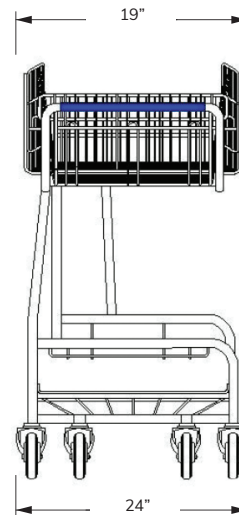
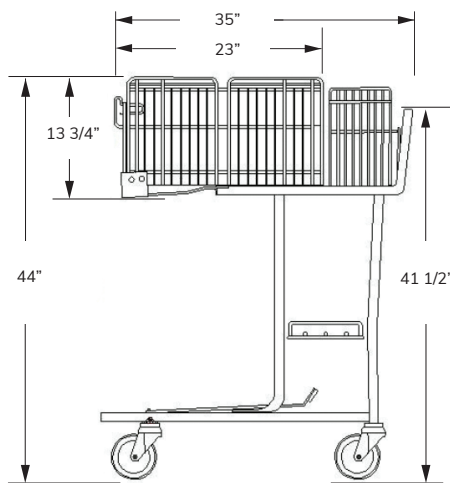

Total Capacity

14,977 in³
245.4 liters

Basket Capacity

4,512 in³
73.9 liters

Nesting Distance

12 3/8 in
31.4 cm

Weight

68 lbs
30.8 kg



KNM440

JUMBO OTC CART

FEATURES:

- Available in any color finish or texture
- Meets all ASTM F2372-15R21 Standards
- Choice of plastic handle and seat color
- Custom logo imprint
- Seat belt
- Rust/weather-resistant finish

FINISH COLORS:



Black Gloss
Textured

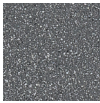

Granite

Additional Finishes available: Textured Granite, Gloss Black, Flat Black, Red, Green, Blue, Orange, Yellow.

PLASTIC COLORS:

Applies to handles and seats.

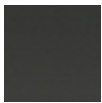

Black

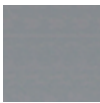

Gray



Red



Blue



Dark Green

Contact your Peggs representative for a complete list of the available plastic colors.

Minimum quantities apply for custom metal finish and plastic colors.

OPTIONAL ACCESSORIES:



Cup Holder, Phone/Coupon
Convenience Tray, Purse Hook



P&H Super Wheels, TPE
Soft and Quiet Runner Wheels



Cart containment systems:
Gatekeeper, Cartronics,
Rocateq, etc.

