



KNM320

LARGE METAL CART

This large capacity cart with a deep basket and hinged lower tray maximizes product carrying capacity while minimizing the aisle footprint. At only 23" wide, this cart is designed for stores with tight aisles.

Gravity-Drop Seat Frame ensures a smooth and effortless closing of the child seat when the gate closes, significantly reducing the chances of seat belts and components getting tangled in the operation.

Double-Rim Wire Construction eliminates sharp edges at all touchpoints around the basket while adding rigidity and strength.

Forever Secure gate design ensures the gate assembly that holds the child can never fall off, or out of the cart.

FEATURES:

- Available in any color finish or texture
- Meets all ASTM F2372-15R21 Standards
- Choice of plastic handle and seat color
- Store name or logo imprint on handle
- Seat belt
- Rust/weather-resistant finish

OPTIONS:

- Cup holder, phone/convenience tray
- Purse hook
- Corner and full-length bumpers
- P&H Super Wheels, TPE Soft and Quiet Runner wheels
- Cart containment: Gatekeeper Systems, Carttronics, Rocateq, etc.

PRODUCT SPECIFICATIONS:

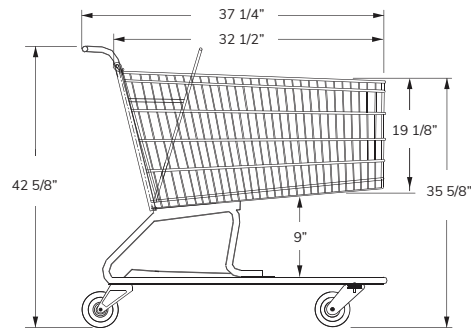
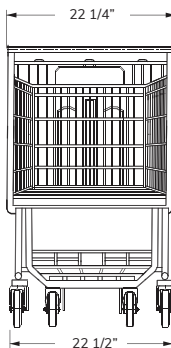

Total Capacity

16,361 in³
268.11 liters

Basket Capacity

13,295 in³
217.87 liters

Nesting Distance

10"
25.4 cm

Weight

56 lbs
25.40 kg

