



Designers and Manufacturers of Retail Solutions for Over 60 Years

KNM220

STANDARD METAL CART



Medium sized metal cart features a narrow design allowing for ease of use and the ability to navigate tight spaces.

The cart's high frame increases shopper comfort and ease of loading and unloading.

Double-Rim Wire Construction eliminates sharp edges at all touch-points around the basket while adding rigidity and strength.

Welded Lower Tray means less maintenance, less rusting and quieter cart operation in store.

Forever Secure gate design ensures the gate assembly that holds the child can never fall off, or out of the cart.

Gravity-Drop Seat Frame ensures a smooth and effortless closing of the child seat when the gate closes, significantly reducing the chances of seat belts and components getting tangled in the operation.

**Photo shown includes optional Corner Bumpers*

PRODUCT SPECIFICATIONS:

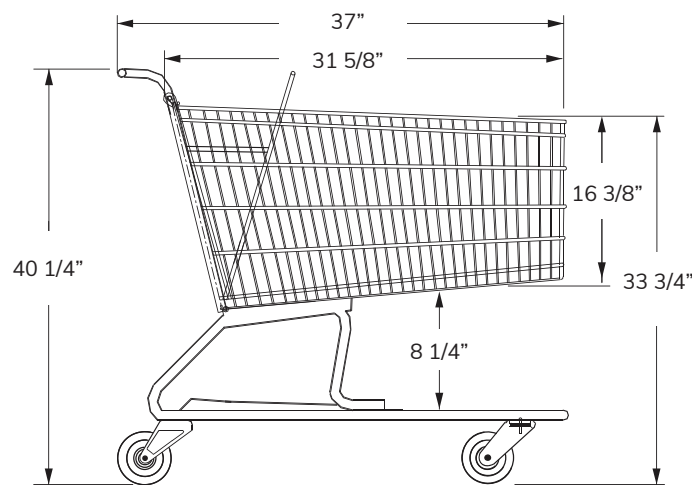
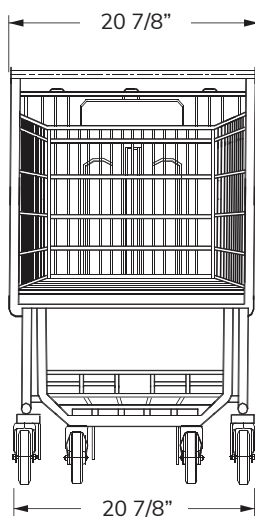

Total Capacity

11,380 in³
186.4 liters

Basket Capacity

8,608 in³
141 liters

Nesting Distance

9 7/8 in
25 cm

Weight

53 lbs
24 kg



KNM220

STANDARD METAL CART

FEATURES:

- Available in any color finish or texture
- Meets all ASTM F2372-15R21 Standards
- Choice of plastic handle and seat color
- Custom logo imprint
- Seat belt
- Rust/weather-resistant finish

FINISH COLORS:



Black Gloss
Textured

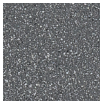

Granite
Textured

Additional Finishes available: Textured Granite, Gloss Black, Flat Black, Red, Green, Blue, Orange, Yellow.

PLASTIC COLORS:

Applies to handle and seats.

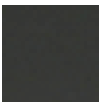

Black

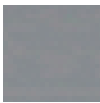

Gray



Red



Blue



Dark Green

Contact your Peggs representative for a complete list of the available plastic colors.

Minimum quantities apply for custom metal finish and plastic colors.

OPTIONAL ACCESSORIES:



Cup Holder, Phone/Coupon
Convenience Tray, Purse Hook



P&H Super Wheels, TPE
Soft and Quiet Runner Wheels



Optional Corner Bumpers
in Standard Black or Gray



Cart containment systems:
Gatekeeper, Cartronics,
Rocateq, etc.

