



Designers and Manufacturers of Retail Solutions for Over 60 Years



# KNM180

## STANDARD METAL CART

Commonly used in drug stores and dollar stores, this medium size metal cart reduces store congestion. Its tall frame allows ease of loading and unloading and increases space in lower tray.

**Double-Rim Wire Construction** eliminates sharp edges at all touch-points around the basket while adding rigidity and strength.

**Forever Secure** gate design ensures the gate assembly that holds the child can never fall off, or out of the cart.

**Gravity-Drop Seat Frame** ensures a smooth and effortless closing of the child seat when the gate closes, significantly reducing the chances of seat belts and components getting tangled in the operation.

*\*Photo shown includes optional Bumpers*

### PRODUCT SPECIFICATIONS:

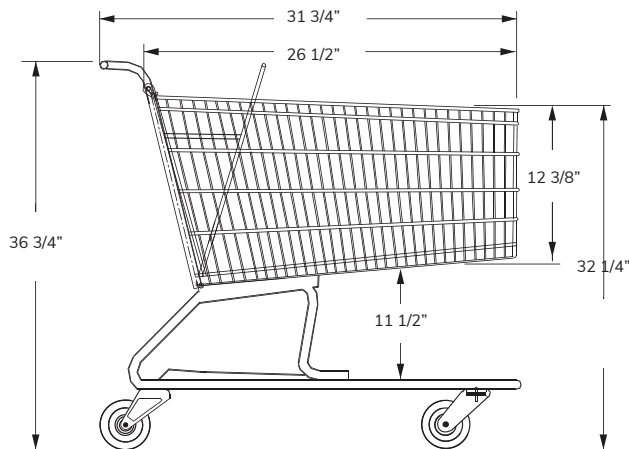
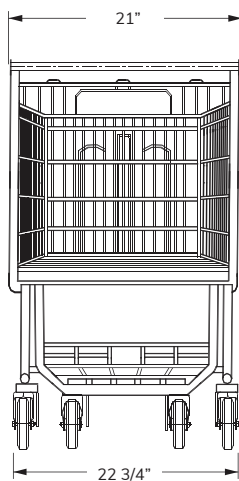

#### Total Capacity

5,279 in<sup>3</sup>  
196.6 liters

#### Basket Capacity

5,279 in<sup>3</sup>  
147.4 liters

#### Nesting Distance

9 1/4 in  
24 cm

#### Weight

39 lbs  
17.7 kg



# KNM180

## STANDARD METAL CART

### FEATURES:

- Available in any color finish or texture
- Meets all ASTM F2372-15R21 Standards
- Choice of plastic handle and seat color
- Custom logo imprint
- Seat belt
- Rust/weather-resistant finish

### FINISH COLORS:



Black Gloss  
Textured

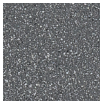

Granite

Additional Finishes available: Textured Granite, Gloss Black, Flat Black, Red, Green, Blue, Orange, Yellow.

### PLASTIC COLORS:

Applies to handles and seats.

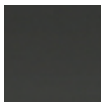

Black

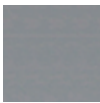

Gray



Red



Blue



Dark Green

Contact your Peggs representative for a complete list of the available plastic colors.

Minimum quantities apply for custom metal finish and plastic colors.

### OPTIONAL ACCESSORIES:



Cup Holder, Phone  
Convenience Tray, Purse Hook



P&H Super Wheels, TPE  
Soft and Quiet Runner Wheels



Optional Corner Bumpers  
in Standard Black or Gray



Cart containment systems:  
Gatekeeper, Carttronics,  
Rocateq, etc.

