



Designers and Manufacturers of Retail Solutions for Over 60 Years



# KNM086

## SINGLE TIER EXPRESS CART

The single basket Convenience Cart features a purse hook, expanded lower tray for bulk product such as toilet paper, cases of wine, large boxes, etc. and a rear small goods basket for additional storage.

Double-rim wire construction eliminates sharp edges at all touchpoints around the basket while adding rigidity and strength.

A spring-loaded lower tray allows larger items to sit flat and prevent the items from falling off while still being able to nest.

The welded child safety warning placard eliminates the chance of missing labels and helps reduce child accident liability.

### PRODUCT SPECIFICATIONS:

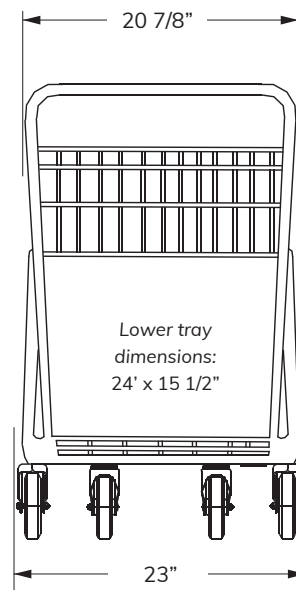
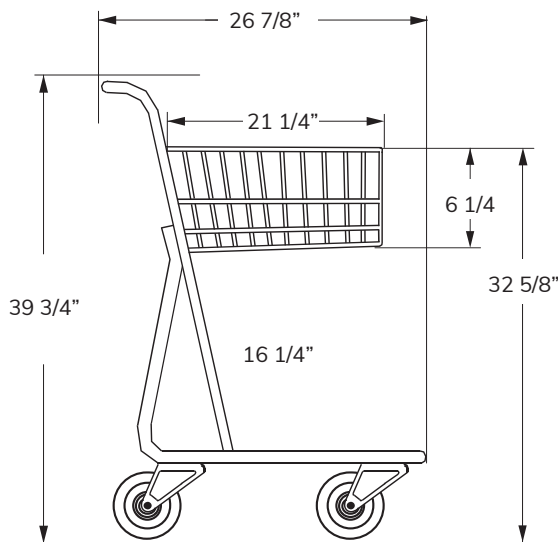

#### Total Capacity

9,751 cu<sup>3</sup> / 200 lbs  
159.8 liters / 90.7 kg

#### Top Basket Capacity

2,356 cu<sup>3</sup> / 50 lbs  
38.6 liters / 22.7 kg

#### Rear Basket Capacity

720 cu<sup>3</sup>  
11.8 liters

#### Lower Tray Capacity

6,675 cu<sup>3</sup> / 150 lbs  
109.4 liters / 68 kg

#### Nesting Distance

9 1/4 in  
23.5 cm

#### Weight

46 lbs  
20.9 kg



# KNM086

## SINGLE TIER EXPRESS CART

### FEATURES:

- Available in any color finish or texture
- Meets all ASTM F2372-15R21 Standards
- Choice of plastic handle color
- Store name or logo imprint on handle
- Rust/weather-resistant finish

### FINISH COLORS:



Black Gloss  
Textured

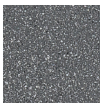

Granite

Additional Finishes available: Textured Granite, Gloss Black, Flat Black, Red, Green, Blue, Orange, Yellow.

### PLASTIC COLORS:

Applies to cart handles.



Black

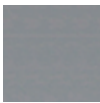

Gray



Red



Blue



Dark Green

Contact your Peggs representative for a complete list of the available plastic colors.

Minimum quantities apply for custom metal finish and plastic colors.

### OPTIONAL ACCESSORIES:



Cup Holder, Coupon/Phone  
Convenience Tray



P&H Super Wheels, TPE Soft  
and Quiet Runner Wheels



Optional Corner Bumpers  
in Standard Black or Gray



Cart containment systems:  
Gatekeeper, Cartronics,  
Rocateq, etc.

