



Designers and Manufacturers of Retail Solutions for Over 60 Years



KNM085

CONVENIENCE CART W/ LOWER TRAY

The double basket Convenience Cart features a lower tray designed to carry jugs of milk or soda.

A welded child safety warning placard eliminates missing labels and helps reduce child accident liability.

PRODUCT SPECIFICATIONS:

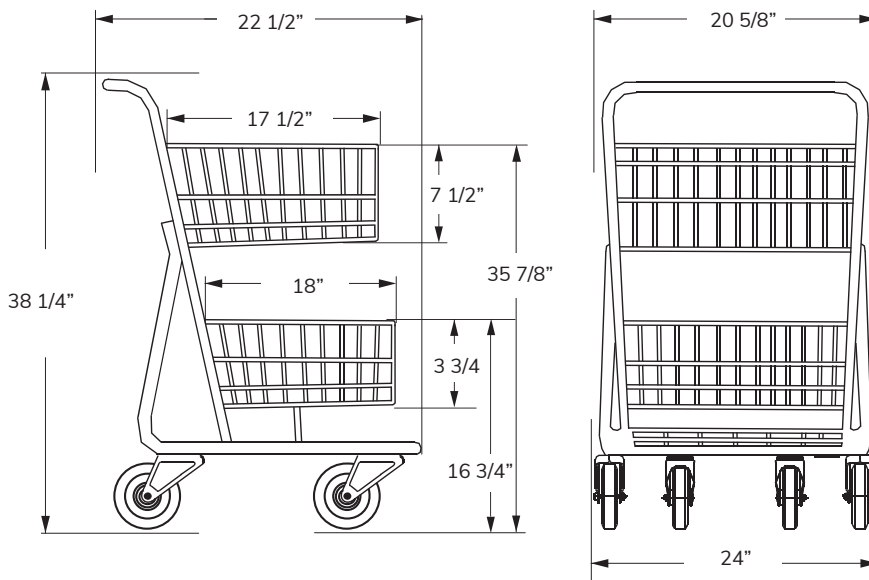

Total Capacity

4,799 cu. in.
78.6 liters

Top Basket Capacity

2,250 cu. in.
36.9 liters

Lower Basket Capacity

1,709 cu. in.
28 liters

Nesting Distance

8 3/8 in.
21.3 cm

Weight

39 lbs
17.7 kg



KNM085

CONVENIENCE CART

FEATURES:

- Available in any color finish or texture
- Meets all ASTM F2372-15R21 Standards
- Choice of plastic handle color
- Store name or logo imprint on handle
- Rust/weather-resistant finish

FINISH COLORS:



Black Gloss
Textured

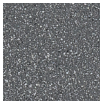

Granite

Additional Finishes available: Textured Granite, Gloss Black, Flat Black, Red, Green, Blue, Orange, Yellow.

PLASTIC COLORS:

Applies to handle.

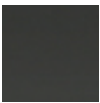

Black

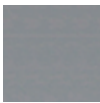

Gray



Red



Blue



Dark Green

Contact your Peggs representative for a complete list of the available plastic colors.

Minimum quantities apply for custom metal finish and plastic colors.

OPTIONAL ACCESSORIES:



Cup Holder, Coupon/Phone
Convenience Tray



P&H Super Wheels, TPE Soft
and Quiet Runner Wheels



Optional Corner Bumpers
in Standard Black or Gray



Cart containment systems:
Gatekeeper, Cartronics,
Rocateq, etc.

