



Designers and Manufacturers of Retail Solutions for Over 60 Years



KNM080

CONVENIENCE CART W/ REAR BASKET

Double basket Convenience Cart is designed to maximize basket shopping capacity. The welded child safety warning placard eliminates missing labels and helps reduce child accident liability.

A small third basket mounts between upper and lower basket to provide additional capacity for small items.

PRODUCT SPECIFICATIONS:

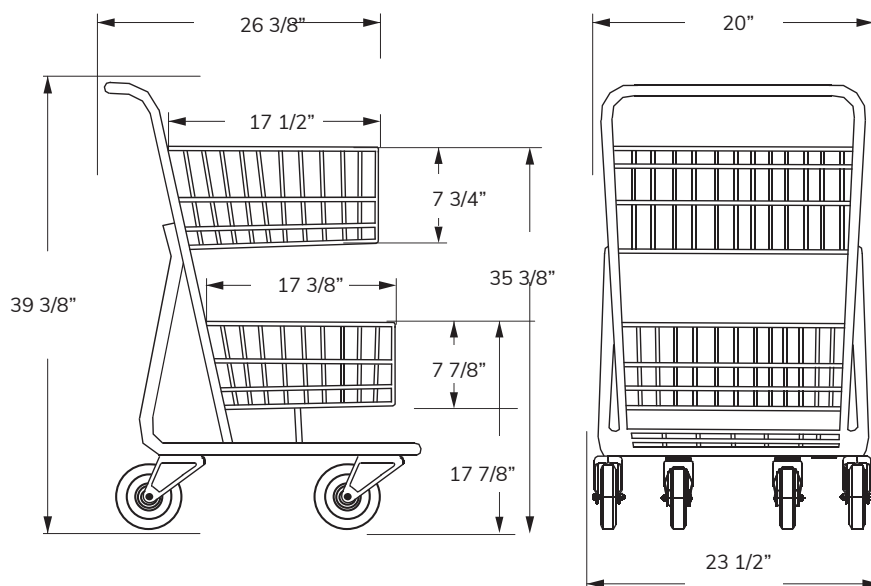

Total Capacity

4,865 in³
79.7 liters

Basket Capacity

2,212 in³
36.25 liters

Nesting Distance

7 1/4 in
18.4 cm

Weight

43 lbs
19.5 kg



KNM080

CONVENIENCE CART W/ REAR BASKET

FEATURES:

- Available in any color finish or texture
- Meets all ASTM F2372 Standards
- Choice of plastic handle color
- Store name or logo imprint on handle
- Rust/weather-resistant finish

FINISH COLORS:



Black Gloss
Textured

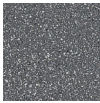

Granite

Additional Finishes available: Textured Granite, Gloss Black, Flat Black, Red, Green, Blue, Orange, Yellow.

PLASTIC COLORS:

Applies to cart handles and seats.

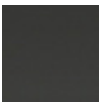

Black

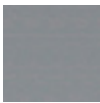

Gray



Red



Blue



Dark Green

Contact your Peggs representative for a complete list of the available plastic colors.

Minimum quantities apply for custom metal finish and plastic colors.

OPTIONAL ACCESSORIES:



Cup Holder, Coupon/Phone
Convenience Tray



P&H Super Wheels, TPE Soft
and Quiet Runner Wheels



Optional Corner Bumpers
in Standard Black or Gray



Cart containment systems:
Gatekeeper, Carttronics,
Rocateq, etc.

