



Designers and Manufacturers of Retail Solutions for Over 60 Years



# KNM079

## CONVENIENCE CART

This double basket Convenience Cart is available with or without a child seat. An optional small third basket mounts between upper and lower basket to provide additional capacity for small items.

*\*Photo shown includes optional Corner Bumper*

### PRODUCT SPECIFICATIONS:

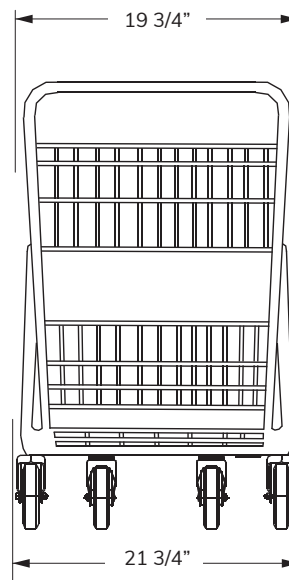
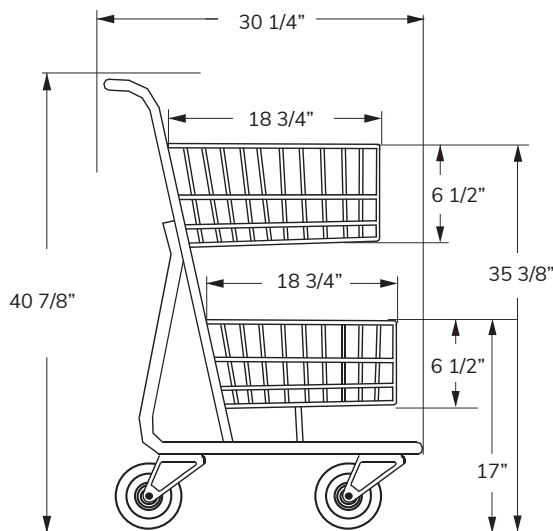

#### Total Capacity

4,040 in<sup>3</sup>  
66.2 liters

#### Basket Capacity

2,020 in<sup>3</sup>  
33.1 liters

#### Nesting Distance

9 in  
20.32 cm

#### Weight

41 lbs  
18.6 kg



# KNM079

## CONVENIENCE CART

### FEATURES:

- Available in any color finish or texture
- Meets all ASTM F2372-15R21 Standards
- Choice of plastic handle and seat color
- Store name or logo imprint on handle
- Seat belt
- Rust/weather-resistant finish

### FINISH COLORS:



Black Gloss  
Textured

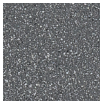

Granite

Additional Finishes available: Textured Granite, Gloss Black, Flat Black, Red, Green, Blue, Orange, Yellow.

### PLASTIC COLORS:

Applies to cart handles and seats.

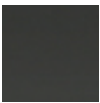

Black

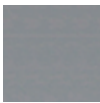

Gray



Red



Blue



Dark Green

Contact your Peggs representative for a complete list of the available plastic colors.

Minimum quantities apply for custom metal finish and plastic colors.

### OPTIONAL ACCESSORIES:



Cup Holder, Coupon/Phone  
Convenience Tray



P&H Super Wheels, TPE Soft  
and Quiet Runner Wheels



Optional Corner Bumpers  
in Standard Black or Gray



Cart containment systems:  
Gatekeeper, Cartronics,  
Rocateq, etc.

