



KNM077

CONVENIENCE CART

The double-basket Convenience Cart which features a rear lower tray and rear milk/soda basket is designed to maximize basket shopping capacity for express shoppers.

A welded child safety warning placard eliminates the occurrence of missing signage to help reduce child accident liability.

Double-rim wire construction eliminates sharp edges at all touchpoints around the basket while adding rigidity and strength.

FEATURES:

- Available in zinc (shown above) or powder-coated finish
- Meets all ASTM F2372 Standards
- Choice of plastic handle color
- Custom logo imprint
- Rust/weather-resistant finish
- Cup holder, phone/convenience tray
- Corner bumpers

OPTIONS:

- P&H Super Wheels, TPE Soft and Quiet Runner wheels
- Cart containment: Gatekeeper Systems, Cartronics, Rocateq, etc.

PRODUCT SPECIFICATIONS:

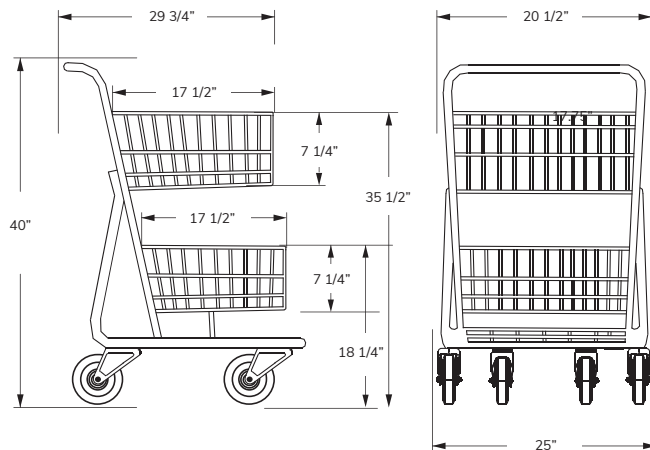

Total Capacity

4,660 in³
76.3 liters

Basket Capacity

2,330 in³
38 liters

Nesting Distance

7 1/2 in
19 cm

Weight

46.75 lbs
21.2 kg

