



Designers and Manufacturers of Retail Solutions for Over 60 Years



KNM075

CONVENIENCE CART

Double basket Convenience Cart designed to maximize basket shopping capacity. Welded child safety warning placard to eliminate missing labels and help reduce child accident liability. Optional small third basket mounts between upper and lower basket to provide additional capacity for small items.

PRODUCT SPECIFICATIONS:

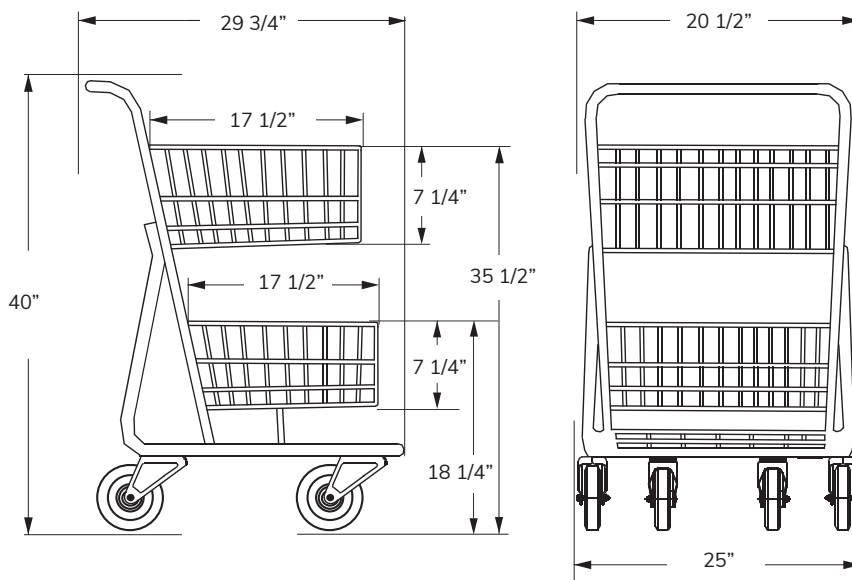

Total Capacity

4,660 cu³
76.3 liters

Basket Capacity

2,330 cu³
38 liters

Nesting Distance

7 1/2 in
19 cm

Weight

36 lbs
16.3 kg



KNM075

CONVENIENCE CART

FEATURES:

- Available in any color finish or texture
- Meets all ASTM F2372-15R21 Standards
- Choice of plastic handle and seat color
- Store name or logo imprint on handle
- Rust/weather-resistant finish

FINISH COLORS:



Black Gloss
Textured

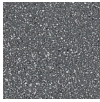

Granite

Additional Finishes available: Textured Granite, Gloss Black, Flat Black, Red, Green, Blue, Orange, Yellow.

PLASTIC COLORS:

Applies to cart baskets, handles and seats.



Black



Gray



Red



Blue



Dark Green

Contact your Peggs representative for a complete list of the available plastic colors.

Minimum quantities apply for custom metal finish and plastic colors.

OPTIONAL ACCESSORIES:



Plastic Cup Holder,
Phone/Convenience Tray,
Purse Hook



P&H Super Wheels, TPE
Soft and Quiet Runner Wheels



Optional Corner Bumpers
in Standard Black or Gray



Cart containment systems:
Gatekeeper, Cartronics,
Rocateq, etc.

