



KNM071

CONVENIENCE CART



Double-basket Convenience Cart—European style. Available with or without child seat. Optional small third basket mounts between upper and lower basket to provide additional capacity for small items.

Double-Rim Wire Construction eliminates sharp edges at all touch-points around the basket while adding rigidity and strength.

Welded Lower Tray means less maintenance, less rusting and quieter cart operation in store.

Forever Secure gate design ensures the gate assembly that holds the child can never fall off, or out of the cart.

Gravity-Drop Seat Frame ensures a smooth and effortless closing of the child seat when the gate closes, significantly reducing the chances of seat belts and components getting tangled in the operation.

FEATURES:

- Available in any color finish or texture
- Meets all ASTM F2372-15R21 Standards
- Choice of plastic handle and seat color
- Seat belt
- Rust/weather-resistant finish

OPTIONS:

- Cup holder, phone/convenience tray
- Purse hook
- Plastic logo panel
- Corner bumpers
- P&H Super Wheels, TPE Soft and Quiet Runner wheels
- Cart containment: Gatekeeper Systems, Carttronics, Rocateq, etc.

PRODUCT SPECIFICATIONS:

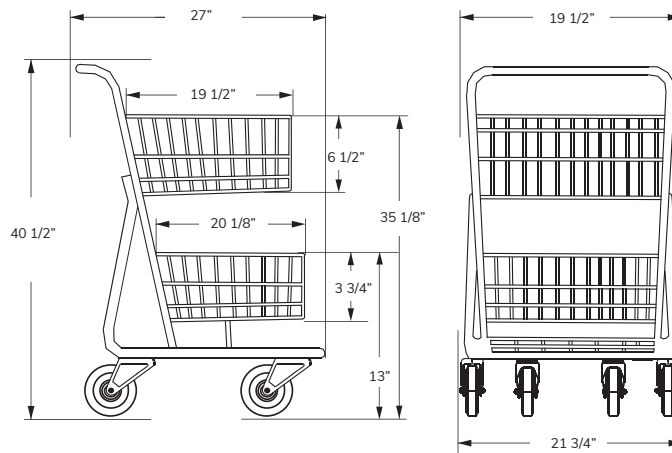

Total Capacity

3,225 in³
52.84 liters

Top Basket

1,948 in³
31.92 liters

Bottom Basket

1,277 in³
20.92 liters

Nesting Distance

8 1/4 in
20.95 cm

Weight

41 lbs
18.59 kg

